

The Drone for Industrial Work

The Skygauge takes ultrasonic testing to the skies. Conduct faster, safer industrial inspections by drone.

Why Skygauge?

WE REINVENTED THE DRONE FOR ULTRASONIC TESTING

Skygauge robotics has reinvented the drone to perform inspections not practical with drones today. Drones are increasingly being used by companies to perform visual inspections, however, there has been limited industry adoption for drone based ultrasonic testing due to technical limitations. There is enormous market demand for drones to do more than just visual inspection due to the risk associated with the current methods of inspection.

THE SKYGAUGE IS SAFER

Performing UT inspections at height puts workers at risk of slips or falls. Using drones eliminates this risk by keeping workers safely on the ground.

MORE COST EFFECTIVE

Current methods require workers to use ropes, man lifts, or scaffolding, costing 5 or 6 figures for a single job. Most of these costs are associated with the access method. Drones eliminate these costs.

AND REDUCES DOWNTIME

A drone performs inspections 5 to 20 times faster resulting in lower maintenance downtime. For large industrial sites, this can save millions in opportunity cost.



Use Cases

Industry applications of the Skygauge Drone



STORAGE TANKS AND SILOS

The surfaces of storage tanks and silos are an optimal use case for the Skygauge Beta drone. These structures have large flat and near-flat surfaces with minimal obstructions that require UT inspections.



STEEL CHIMNEYS

External surfaces of steel chimneys have few obstructions and are challenging to access using rope access or scaffolding. Using the Skygauge drone, most surfaces of the chimney can be reached and inspected with ease.



FLARE STACKS

Flare stacks with large outer diameters meet the operational criteria for the Skygauge Beta. Using the Skygauge, flare stacks can be inspected while in-service, leading to large savings in operational downtime.



SHIP INSPECTIONS

Cargo holds, ship hulls, and ballast tanks need routine inspection. These inspections take weeks to complete with current methods. The Skygauge navigates indoor and outdoor areas to take readings quickly and effectively.



PIPE INSPECTIONS

Inspections of industrial site piping, as per API 570 standards, typically require draining and stopping pipelines for internal checks. However, Skygauge allows for external inspections without interrupting pipeline operations.

Inspections at any angle

Vertical and Horizontal Capabilities

The Skygauge's payload arm can be rotated 90 degrees up and down, enabling inspections in tricky areas, such as the tops and bottoms of pipelines. This is where most of the erosion happens, making this a critical capability for the Skygauge. Advanced stability control features, and cameras that pivot alongside the payload make it easy for pilots to fly Skygauge in vertical and horizontal regimes.



Angled Contact

In addition to the pivoting payload, the drone itself can use its gimballed thrust to tilt up or down, enabling inspection of sloped surfaces such as the roofs of storage tanks or the sides of pipes. This capability is critical, to ensure that the Skygauge is able to inspect any point, regardless of asset geometry.

Skygauge Inspection System



Inspection Team

The inspection team comprises of one drone pilot and one ultrasonic testing technician. These teams can quickly setup the drone in under 20 minutes and start taking UT readings. The pilot controls the drone with a ground station and the inspector validates the readings on an inspection computer.

Inspection System

The Skygauge system is portable and has been designed to be transported on airlines eliminating the need to ship components to the job site beforehand. Training of these teams is completed in 5 business days.



Confined Spaces

PERFORM INSPECTIONS IN GPS DENIED AREAS

The Skygauge performs UT readings without the need for GPS in areas with minimal wind. This use case is intended for internal ship and tank inspections.

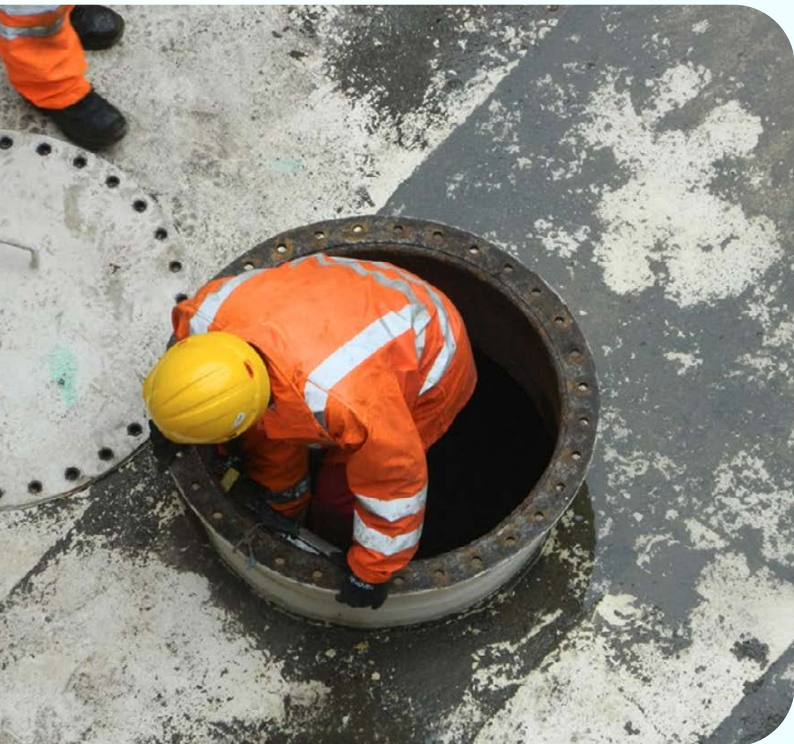

MANHOLE ACCESS

The Skygauge design naturally folds onto itself to fit into tighter spaces when not in operation. For extra access requirements the drone can be disassembled to fit in 55cm manways to enter most access hatches. The drone will then be reassembled inside the tank to begin the work.

Ultrasonic Testing Reading

UT Data collection

The Skygauge probe hosts several different systems and sensors to collect UT thickness data. Once the pilot navigated the drone into an inspection area, the pilot engages the contact mode. With the feedback from the forward facing LiDAR aid the drone moves forward at a fixed speed. Right before contact is made couplant is automatically dispensed.

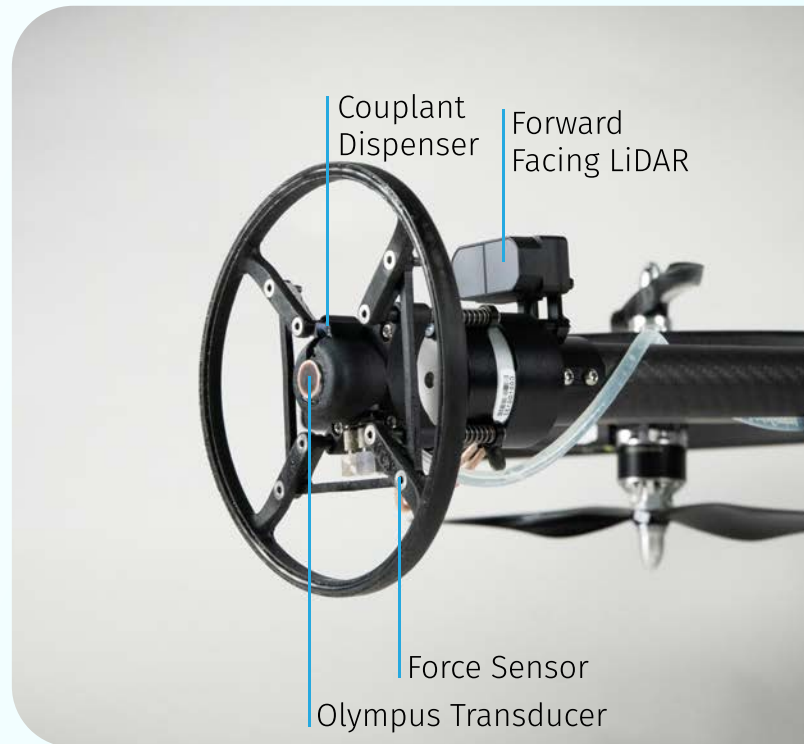

GVI View



UT Waveform Data



Waveform data

During contact, the drone automatically adjusts its angle with feedback from the force sensor. These adjustments mimic the precision of hand tested readings. The live waveform is verified by the UT inspector and the pilot flies the drone to the next inspection point. All data is stored on an SD card that is exported to the inspection computer after the job is completed. The inspection computer automatically generates inspection reports with the data.

Payloads



Payload

Ultrasonic Testing

Bespoke ultrasonic testing probe for spot thickness ultrasonic testing of tall structures like chimneys, storage tanks, or the sides of ships.



Payload

Dry Film Thickness

A gauge for measuring the thickness of paint and protective coatings for industrial assets, ensuring they remain safe from corrosion.



Payload

Scrubbing

A wire brush attachment to remove rust patches and prepare surfaces for further inspection.



Payload

EMAT

Specialized thickness scanning tool for metal structures – does not require couplant and can be done with minimal surface preparation.

SKYGAUGE DRONE

Specifications

AIRCRAFT

CONFIGURATION :	X8 Coaxial thrust vectoring
DEPLOYED DIMENSIONS :	90 cm x 90 cm x 48 cm
FOLDED DIMENSIONS :	64 cm x 64 cm x 40 cm
PROPULSION SYSTEM :	8x Thrust Motors 8x Servo Motors
EMPTY WEIGHT :	4 kg
BATTERY WEIGHT :	1.3 kg
MAX TAKE-OFF WEIGHT :	8 kg
FLIGHT TIME :	8 minutes
MAX HOVER ANGLE :	45° Pitch and Roll
MAX WIND RESISTANCE :	10 Knots
GNSS :	Dual GPS + GLONASS + BeiDou + Galileo
OPERATING TEMPERATURE :	-20°C to 40°C
HOVERING PRECISION :	Vertical: ±2.5 cm Horizontal: ±1.0 cm

ULTRASONIC GAUGE

THICKNESS RANGE :	0.080 mm to 635.00 mm
MATERIAL VELOCITY RANGE :	0.508 mm/μs to 13.998 mm/μs
RESOLUTION MODES :	Low: 0.1 mm Standard: 0.01 mm High: 0.001 mm

TRANSDUCER

TRANSDUCER:	D7906
FREQUENCY:	5 MHz
TYPE :	Dual Element
TIP DIAMETER :	11 mm
THICKNESS RANGE :	2 mm to 50 mm
COATING THICKNESS:	0.125 mm to 5 mm
COAT TYPE:	Non-metallic
SURFACE TEMPERATURE :	-20°C to 200°C



SKYGAUGE DRONE

Specifications

BATTERY

BATTERY TYPE :	Dual Pack Li Po 6S HV
RATED CAPACITY :	2x 4350 mAh
NOMINAL VOLTAGE :	22.8 V
ENERGY :	2x 99.9 Wh
CHARGING TIME :	60 minutes
WEIGHT :	2x 625 g
OPERATING TEMPERATURE :	5°C to 30°C
CHARGING TEMPERATURE :	5°C to 30°C
CHARGER :	Skygauge Charging Station

CAMERA

VIDEO RESOLUTION :	1920 x 1080 at 60 fps
PHOTO FORMATS :	JPG
VIDEO FORMATS :	MP4
STREAMING RESOLUTION :	1920 x 1080 60 fps

RADIO COMMUNICATION SYSTEM

OPERATING FREQUENCIES :	2.402 – 2.482 GHz
MODULATION:	DIGITAL MODULATION QPSK FEC 3/4
TRANSMISSION POWER:	1 mW - 1000mW
TRANSMISSION DISTANCE :	300m line of sight
OPERATING TEMPERATURE :	0 °C to 40 °C

